

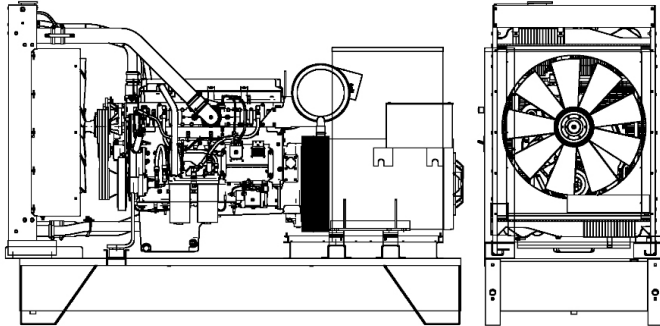

POWERFULL "B"



For illustrative purposes only

ENGINE

| | |
|-----------------------------|---------------------------|
| Description | HYUNDAI(DOOSAN) |
| Engine model | DP180LBF |
| Cylinders | 10 |
| RPM speed | 1800 |
| Cubic capacity | 18.27 l |
| Air intake | Turbocharged |
| Standard voltage | 24 Vdc |
| Optional voltage | Vdc |
| Sae | 1-14 |
| BMEP | 2680 kPa |
| Cooling | Water |
| Flywheel P.R.P. Power net | 577.0 kW |
| Flywheel E.P. Power net | 637.0 kW |
| Fuel Cons. at 100% (E.P.) | 165.3 l/h |
| Fuel Cons. at 100% (P.R.P.) | 150.7 l/h |
| Fuel Cons. at 75% (P.R.P.) | 114.2 l/h |
| Fuel Cons. at 50% (P.R.P.) | 77.7 l/h |
| Fuel Cons. at 25% (P.R.P.) | 41.2 l/h |
| Electronic regulator | Standard |
| Precision class | G3 |
| Oil quantity | 36.0 l |
| Engine Antifreeze capacity | 21.0 l |
| Radiator type | TR |
| Heat from radiator | 448.0 kW |
| Heat from exhaust | 620.0 kW |
| Heat from radiation | 63.0 kW |
| Exhaust temperature | 540 °C |
| Cooling air flow | 850.0 m ³ /min |
| Combustion air flow | 45.5 m ³ /min |
| Exhaust gas flow | 141.0 m ³ /min |
| TA Luft | N |
| TA Luft/2 | N |
| EPA | N |
| Stage | N |

MAIN DATA

| | |
|------------------------|-----------------------|
| Continuous power (PRP) | 685.00 kVA |
| Continuous power (PRP) | 548.00 kW |
| Emergency power (E.P.) | 750.00 kVA |
| Emergency power (E.P.) | 600.00 kW |
| VAC - HZ - cos(fi) | 460 - 60 - 0.8 |

DIMENSIONS AND WEIGHT

| | |
|--------|---------|
| Width | 1410 mm |
| Length | 3440 mm |
| Height | 2150 mm |
| Weight | 4200 kg |

ALTERNATOR

| | |
|----------------------|-------------|
| Description | STAMFORD |
| Alternator model | HC15F |
| P.R.P. Power | 800.0 kVA |
| E.P. Power | 878.0 kVA |
| Connection | Series star |
| Phases | 3FN |
| Winding | 311 |
| Terminal Number | 12 nr. |
| IP Protection | 23 |
| Electronic regulator | AS440 |
| Precision | 1.0 ± % |

BASEFRAME

| | |
|-----------------|-------|
| Model | T3 |
| Standard tank | 900 l |
| Optional tank | 0 l |
| Oversized tank* | 0 l |

CANOPY & SILENCER

| | |
|--------------------------|-------------|
| Canopy model | Not present |
| Silencer model | MS 30 |
| Silencer outlet diameter | 140.0 mm |

Standard reference conditions temperature 25°C, altitude 100m asl, relative humidity 30%, atmospheric pressure 100 kPa (1 bar), power factor 0.8 lag, balanced load - non distortional. Fuel consumption is nominal and refers to specific weight 0.850kg/l. Sound power values refer to free field conditions: the installation site may influence the values. Dimensions, weights and other specifications contained in the technical data sheet and related attachments are nominal, subject to tolerances and refer to the model with standard equipment; any optional and additional equipment/accessories can modify weight, dimensions, performance. **P.R.P. - Prime Power-Continuous power at variable load:** The power that a genset can supply in continuous service at a variable load for an unlimited number of hours per year while respecting the maintenance intervals established in the environmental conditions stated by the Manufacturer, according to ISO8528-1. The average power supplied over time and any applicable overload must be less than the percentages stated by the Manufacturer. **E.P. - Emergency power:** This is the maximum power that a generating set can deliver for a limited number of hours per year while complying with the maintenance frequency stipulated under the environmental conditions set by the Manufacturer. The number of hours per year is determined by the engine manufacturer. The average power output over time must be lower than the percentages set by the engine manufacturer. Overloading is not allowed.

The data contained in this document is nominal and refers to the standard equipped model and is not binding. Visa S.p.A. reserves the right to revise the information without notice per our policy of continuous product development and improvement.

